

TILT MOUNT

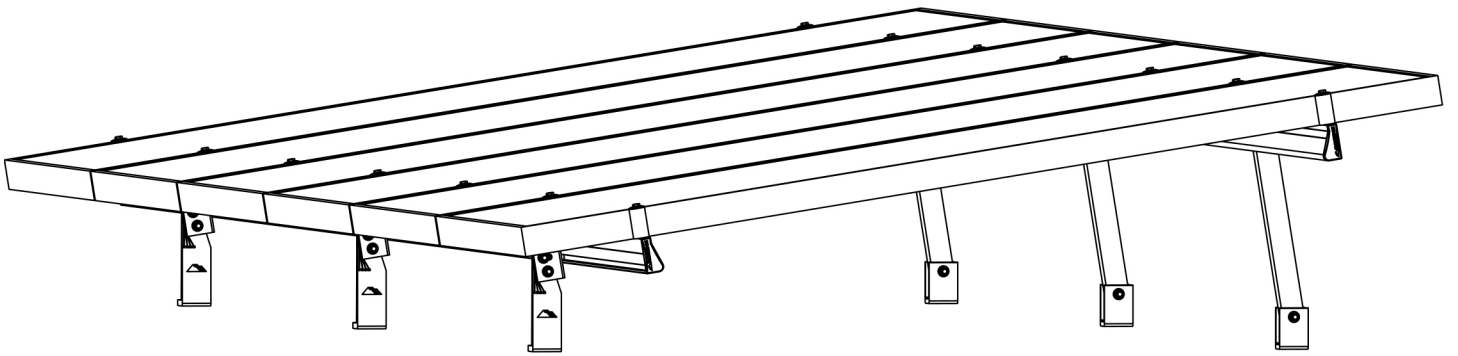

CONTENTS

DISCLAIMER	1
RATINGS	2
MARKINGS	2
CHECKLIST	3
1. ATTACH BASES	4
2. ADD TILT LEGS	4
3. PLACE RAILS	5
4. SECURE LUGS	5
5. SECURE MODULES	6
CAMO	7
EXPANSION JOINTS	8
ELECTRICAL DIAGRAM	9
END CAPS	10
WIRE CLIPS	10
SYSTEMS USING ENPHASE MICROINVERTERS OR SUNPOWER AC MODULES	10
MICROINVERTER KITS	11
SYSTEMS USING MICROSTORAGE PRODUCTS	11
FRAMELESS MODULE KITS	12
MODULE COMPATIBILITY	13-19
FRAMLESS MODULE COMPATIBILITY	20

DISCLAIMER

This manual describes proper installation procedures and provides necessary standards required for product reliability. Warranty details are [available on website](#). All installers must thoroughly read this manual and have a clear understanding of the installation procedures prior to installation. Failure to follow these guidelines may result in property damage, bodily injury or even death.

IT IS THE INSTALLER'S RESPONSIBILITY TO:

- Ensure safe installation of all electrical aspects of the array. All electrical installation and procedures should be conducted by a licensed and bonded electrician or solar contractor. Routine maintenance of a module or panel shall not involve breaking or disturbing the bonding path of the system. All work must comply with national, state and local installation procedures, product and safety standards.
- Comply with all applicable local or national building and fire codes, including any that may supersede this manual.
- Ensure all products are appropriate for the installation, environment, and array under the site's loading conditions.
- Use only IronRidge parts or parts recommended by IronRidge; substituting parts may void any applicable warranty.
- Review the [Design Assistant](#) and [Certification Letters](#) to confirm design specifications.
- Ensure provided information is accurate. Issues resulting from inaccurate information are the installer's responsibility.
- Ensure bare copper grounding wire does not contact aluminum and zinc-plated steel components, to prevent risk of galvanic corrosion.
- If loose components or loose fasteners are found during periodic inspection, re-tighten immediately. Any components showing signs of corrosion or damage that compromise safety shall be replaced immediately.
- Provide an appropriate method of direct-to-earth grounding according to the latest edition of the National Electrical Code, including NEC 250: Grounding and Bonding, and NEC 690: Solar Photovoltaic Systems.
- Disconnect AC power before servicing or removing modules, AC modules, microinverters and power optimizers.
- Review module manufacturer's documentation for compatibility and compliance with warranty terms and conditions.

RATINGS

UL 2703 LISTED



#5003339

Conforms to UL STD 2703 Standard for Safety First Edition: Mounting Systems, Mounting Devices, Clamping/Retention Devices, and Ground Lugs for Use with Flat-Plate Photovoltaic Modules and Panels

- Scope of Evaluation includes bonding, grounding, mechanical loading, and fire classification
- Max Overcurrent Protective Device (OCPD) Rating: 40A
- Max Module Size: 30.5 ft²
- Module Orientation: Portrait or Landscape
- System Design Load Rating: 10 PSF downward, 5 PSF upward, 5 PSF lateral
- Actual system structural capacity including spans and cantilevers is defined by PE stamped [certification letters](#)
- CAMO Specific Ratings Load Rating: 50 PSF downward, 50 PSF upward, 15 PSF lateral

Certified to CSA TIL No. A-40 Photovoltaic Module Racking Systems

- Load Rating: 2400 PA [50 PSF]

Class A System Fire Rating Per UL 2703

- Any System Tilt with Modules Types 1, 2, 3, 13, 19, 25 & 29 on Low Slope Roofs (≤ 9.5 degrees)
- Any System Tilt with Module Types 1 & 2 on Steep Slope Roofs (> 9.5 degrees)
- Any module-to-roof gap is permitted, with no perimeter guarding required. This rating is applicable with any third-party attachment
- Class A rated PV systems can be installed on Class A, B, and C roofs without affecting the roof fire rating

Structural Certification

- Designed and Certified for Compliance with the International Building Code & ASCE/SEI-7

MARKINGS

Product markings are located on the South Tilt Leg.

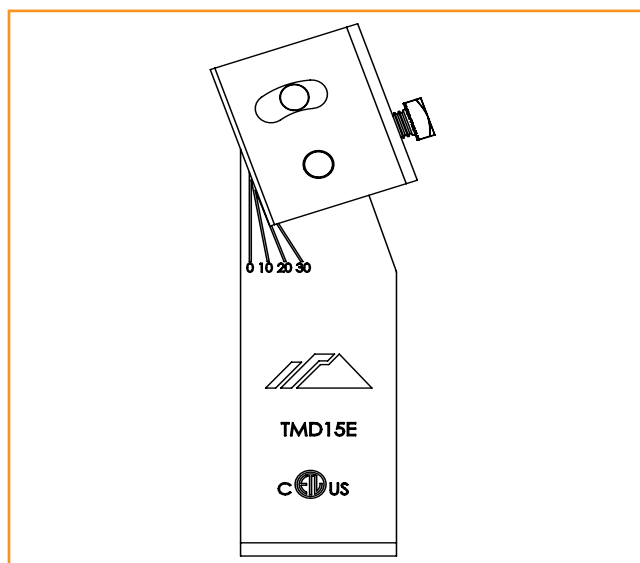

CHECKLIST

PRE-INSTALLATION

- Verify module compatibility. See [Page 13](#) for info.

TOOLS REQUIRED

- Cordless Drill (non-impact)
- Impact Driver (for lag bolts)
- Torque Wrench (0-250 in-lbs)
- 5/16" Socket
- 7/16" Socket
- 9/16" Socket (deep)
- String Line

TORQUE VALUES

- Tilt Leg Nuts (9/16" Socket): 250 in-lbs
- Module Grounding Lug
 - Grounding Nut (7/16" Socket): 60 in-lbs
 - Grounding Lug Terminal Screws (7/16" Socket): 20 in-lbs
- Module Grounding Lug
 - Grounding Nut (7/16" Socket): 60 in-lbs
 - Grounding Lug Terminal Screws (7/16" Socket): 20 in-lbs
- Universal Fastening Objects (7/16" Socket): 80 in-lbs
- Microinverter Kit Nuts (7/16" Socket): 80 in-lbs
- Frameless Module Kit Nuts (7/16" Socket): 80 in-lbs

- If using previous version of: Integrated Grounding Mid Clamps, End Clamps, and Expansion Joints please refer to Alternate Components Addendum (Version 2.0)
- Unless otherwise noted, all components have been evaluated for multiple use. They can be uninstalled and reinstalled in the same or new location.

IRONRIDGE COMPONENTS

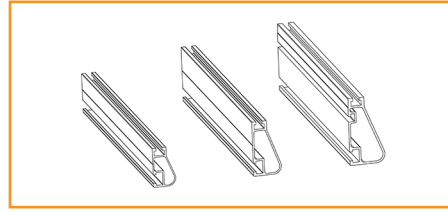

XR Rail

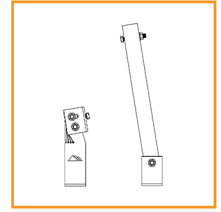

Tilt Leg Kit



Wire Clip

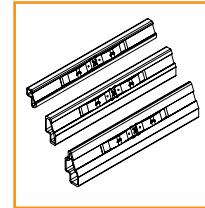

BOSS

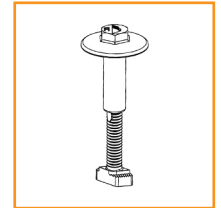

UFO (30-46mm)

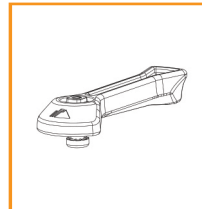

CAMO

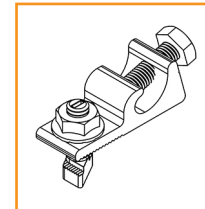

Rail Grounding Lug

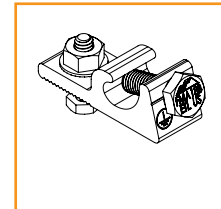

Module Grounding Lug

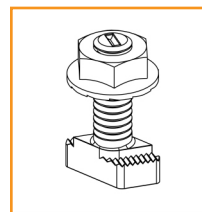

Microinverter Kit



End Cap

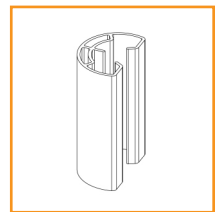

Stopper Sleeve

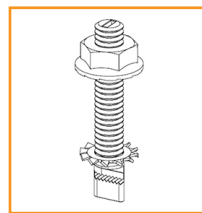

Frameless Module Kit

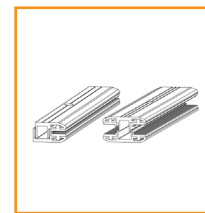

Frameless End/Mid Clamp

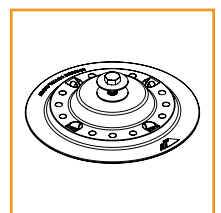

Flat Roof Attachment

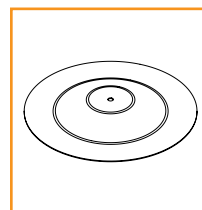

Membrane Flashing

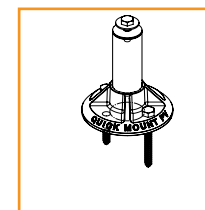

QM QBase Mount

1. ATTACH BASES

Mark locations for Flat Roof Attachment. Type, size, and quantity of roof screws to be specified by Structural Engineer. Fastener size not to exceed #15. Screws should be installed symmetrically to each other. If using a membrane flashing, remove the silicone washer's protective liner prior to attaching the membrane. Ensure membrane flashing is compatible with existing roofing material.

Additional tested or evaluated third-party roof attachments:

- [S-5! Standing Seam Metal Roof Clamps](#) - Certification of metal roof clamps includes bonding to both painted and galvalume metal roofs. Tighten S-5! and S-5! Mini set screws to 130-150 in-lbs (≥ 24 gauge) or 160-180 in-lbs (22 gauge) roofs. Tighten S-5! M10 bolt to 240 in-lbs or S-5! Mini M8 bolt to 160 in-lbs. Use the following fastening guidelines for other S-5! roof clamps: ProteaBracket™ - firmly seat roof screws and tighten hinge bolt to 225 in-lbs; RibBracket™ - firmly seat roof screws and tighten M8 bolt (M8-1.25 x 22mm sold separately) to 160 in-lbs; and SolarFoot™ - firmly seat roof screws and tighten M8 flange nut to 160 in-lbs.

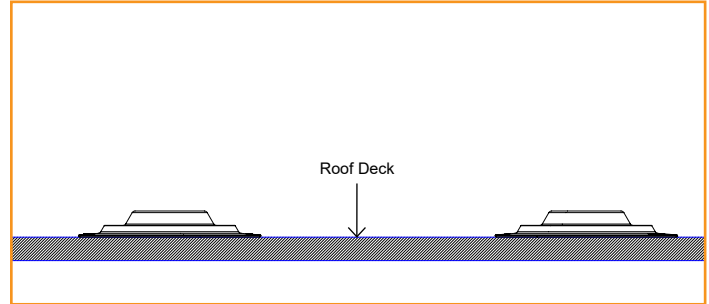

2. ADD TILT LEGS

A. ASSEMBLE SOUTH LEGS

Mount South Tilt Leg Assembly to southern row of roof attachments. The IronRidge logo should face east to ensure proper South Leg orientation. Tighten Flat Roof Attachment hardware to **250 in-lbs**. If using a third-party roof attachment refer to manufacturer's instructions for proper tightening torque.

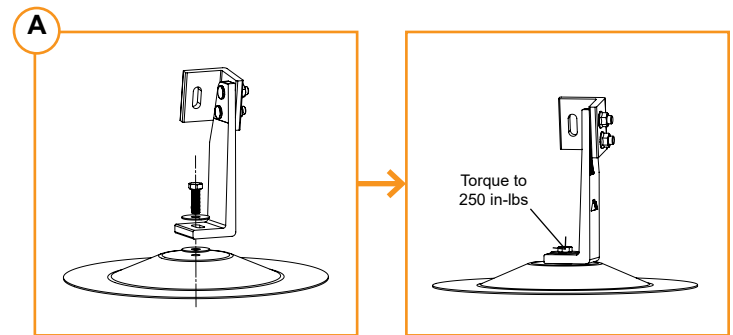

B. SET ANGLE

Set top pivot bracket of South Tilt Leg to the desired angle using the angle indicator on the face of the leg. Finger tighten bolts to allow for adjustment if necessary.

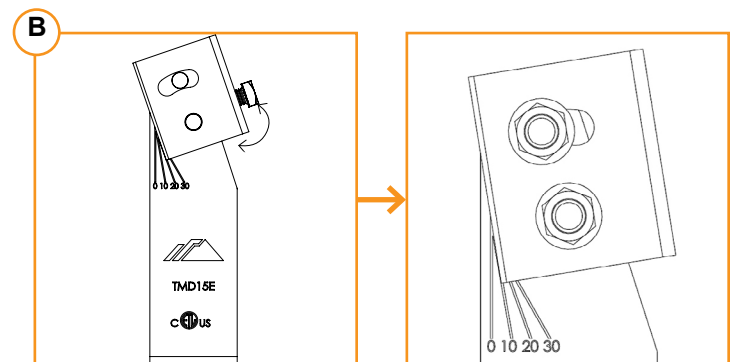

C. ASSEMBLE NORTH LEGS

Mount U-foot to northern row of roof attachments. Tighten Flat Roof Attachment hardware to **250 in-lbs**. If using a third-party roof attachment refer to manufacturer's instructions for proper tightening torque. Mount North Tilt Leg to northern row of U-feet and loosely secure hardware.

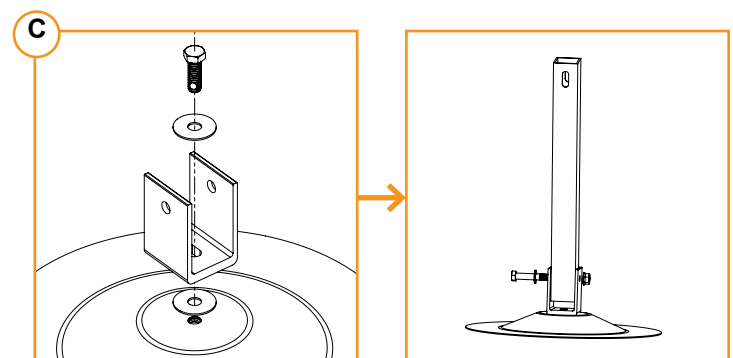

3. PLACE RAILS

A. CONNECT SPLICES

Use BOSS (Bonded Structural Splice), as needed, to join multiple sections of Rail.

BOSS - Bonded Structural Splice

Insert BOSS into first Rail up until the Alignment Tab. Slide second Rail fully into place.

- Rows using BOSS and exceeding 100 feet of Rail must use [Expansion Joints](#).
- Boss Splices may be installed any location within a span.
- UFO and Bonding Hardware must be installed 1" away from the point where two Rails join together.

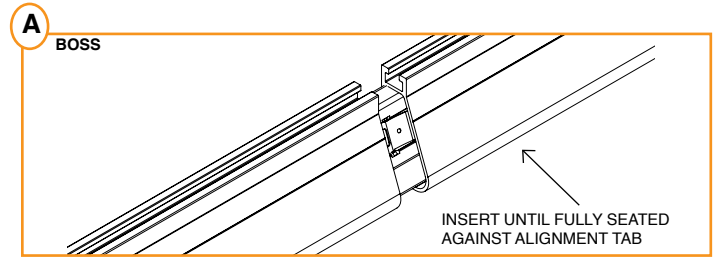

B. ATTACH SOUTH RAILS

Slide 1" long bonding bolt into side-facing rail slot. Mount rail to pivot bracket of South Legs and loosely tighten nuts.

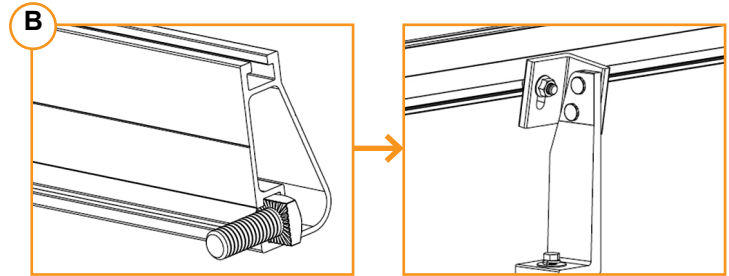

C. ATTACH NORTH RAILS

Slide 2.25" bonding bolt into side-facing rail slot. Mount rail to top of North Legs. Tighten all 3/8" hardware to **250 in-lbs** once rails are square.

- Use a straight edge to ensure South and North rails are on the same plane. An extra section of rail works well.
- Rails can mount on either north or south side of North Tilt Leg.

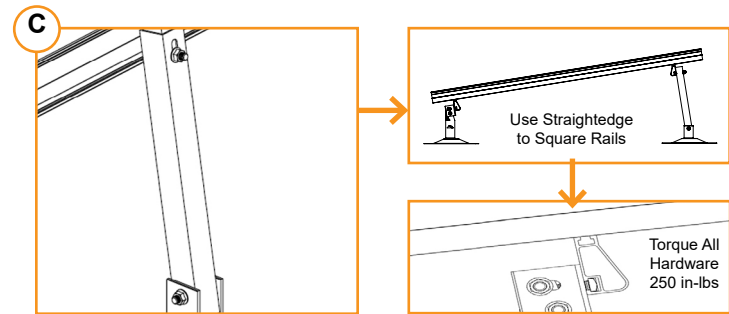

4. SECURE LUGS

Grounding Lugs

Only one Grounding Lug (Rail or Module) required per continuous subarray, regardless of subarray size (Unless frameless modules are used, see [Page 12](#)).

- Grounding Lugs are intended to for use with one solid or stranded copper wire, conductor size 10-4 AWG.

Rail Grounding Lug

Insert T-bolt in Top Rail slot and torque Hex Nut to **80 in-lbs**. Install a minimum 10 AWG solid copper or stranded grounding wire. Torque terminal screw to **20 in-lbs**.

- Rail Grounding Lugs can be installed anywhere along the Rail and in either orientation shown.

Module Grounding Lug

Insert Bolt through Module Manufacturer approved grounding location and torque Hex nut to **60 in-lbs**. One Module Grounding Lug may be installed to one module per continuous array. Install a minimum 10 AWG solid copper or stranded grounding wire. Torque terminal screw to **20 in-lbs**.

- If using Enphase microinverters or Sunpower AC modules, Grounding Lugs may not be needed. See [Page 11](#) for more info.
- Refer to module manufacturer manual for grounding instructions.

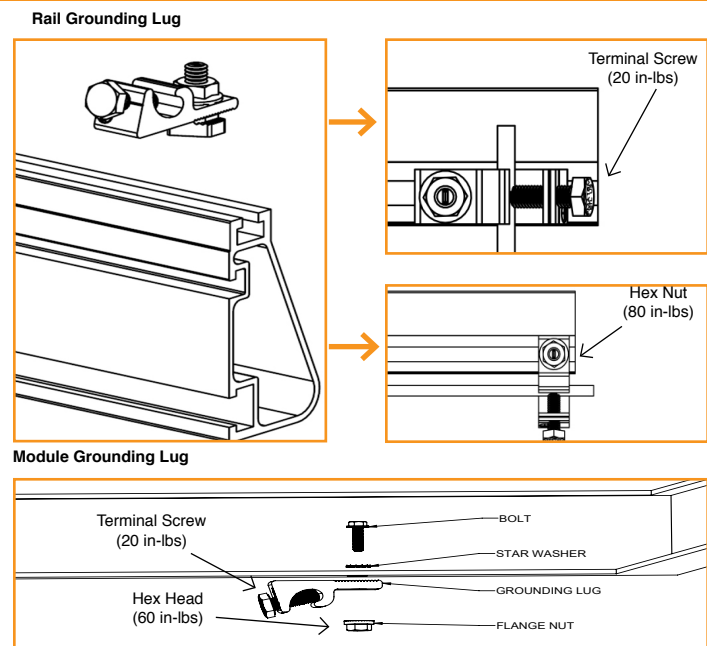

5. SECURE MODULES

A. SECURE FIRST END

Place first module in position on rails, a minimum of 1" from rail ends. Snap Stopper Sleeves onto UFO. Fasten the module to the rail with the UFO, ensuring that the UFO is hooked over the top of the module. Torque to **80 in-lbs**.

- Ensure rails are square before placing modules.
- Hold Stopper Sleeves on end while torquing to prevent rotation.
- If using CAMO instead of UFO + Stopper Sleeve, refer to [Page 7](#) for CAMO installation procedure.
- UFO can be installed on modules 30 to 46mm.

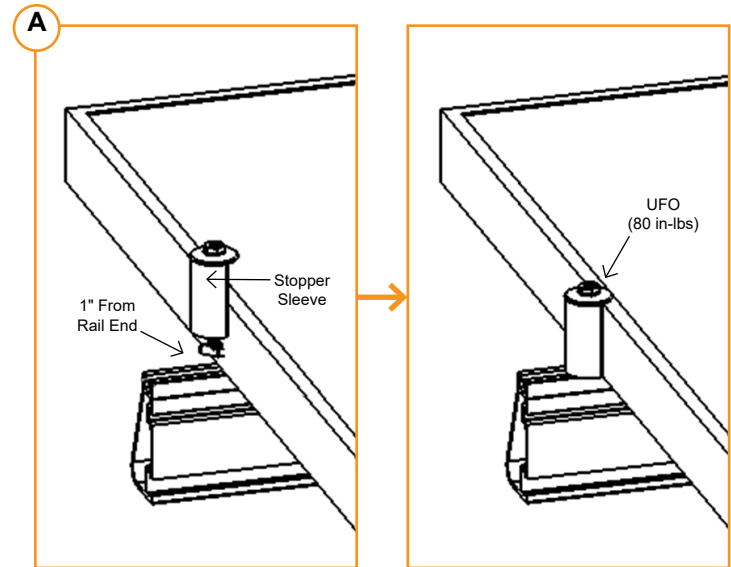

B. SECURE NEXT MODULES

Place UFO into each rail, placing them flush against first module. Slide second module against the UFO. Torque to **80 in-lbs**. Repeat for each following module.

- When reinstalling UFO, move modules a minimum of 1/16" so UFOs are in contact with a new section of module frame.
- When UFOs are loosened and re-tightened, ensure UFO T-bolt bottoms out in rail channel before re-torquing UFO to achieve full engagement between T-bolt and rail.
- If using Wire Clips, refer to [Page 10](#).

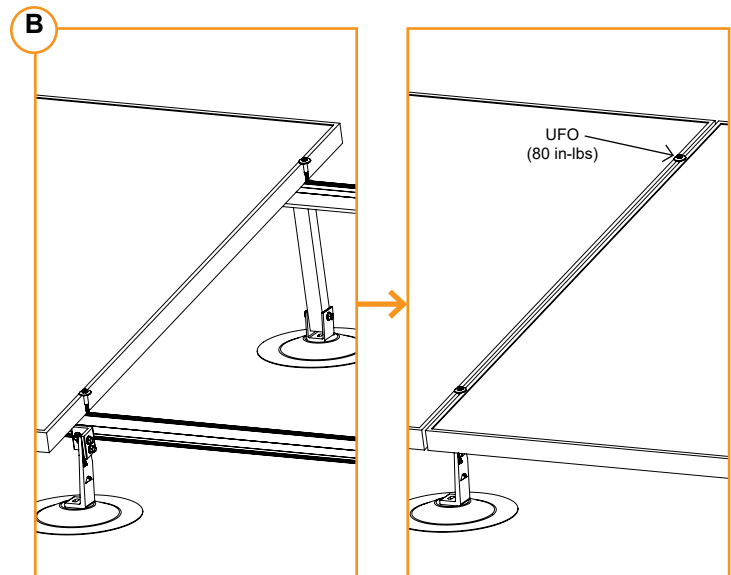

C. SECURE LAST END

Place last module in position on rails, a minimum of 1" from rail ends. Snap Stopper Sleeves onto UFO. Secure UFO on rail, ensuring it is hooked over the top of the module. Torque to **80 in-lbs**.

- Hold Stopper Sleeves on end while torquing to prevent rotation.
- Repeat all steps for each following row of modules, leaving a minimum 3/8" gap between rows.
- If using CAMO instead of UFO + Stopper Sleeve, refer to [Page 7](#) for CAMO installation procedure.

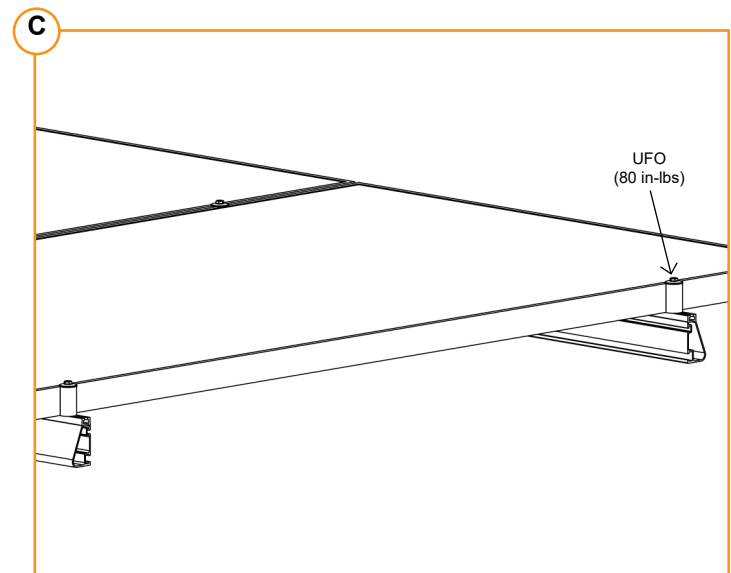

A. SLIDE INTO RAIL

Slide CAMO into rail channel far enough to clear the module frame. CAMO requires 6" of clearance from end of rail.

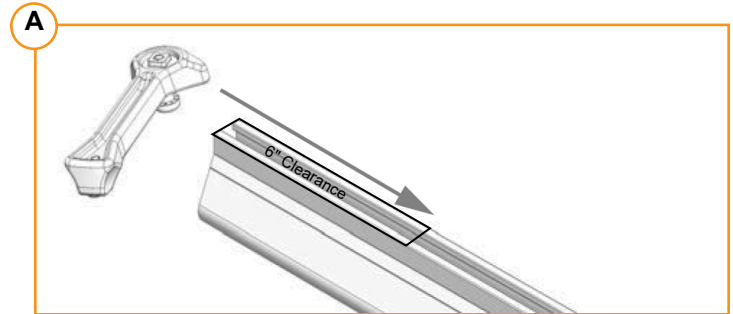

B. PLACE MODULE

Place module on rails (module cells not shown for clarity). When installing CAMO the module can overhang the rail no more than 1/4".

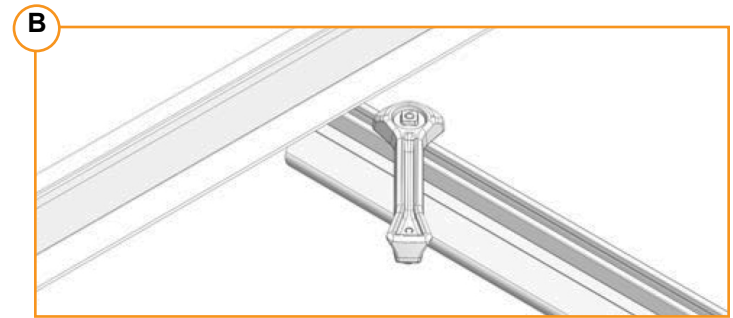

C. PULL TOWARDS END

Pull CAMO towards rail ends, at 45 degree angle, so the bonding bolt contacts the module flange edge.

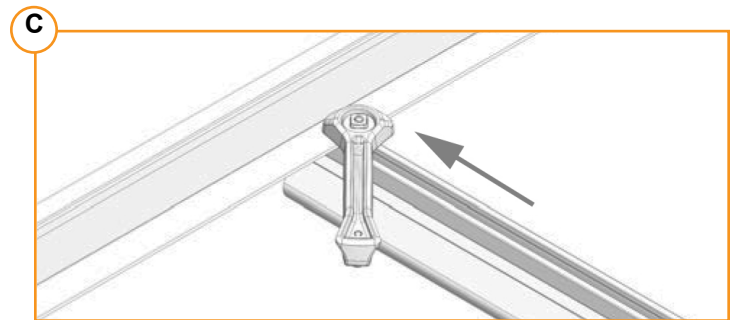

D. SECURE TO FRAME

Rotate handle with an upwards motion until CAMO snaps into rail channel. Ensure CAMO bonding pins are fully seated on top of module frame.

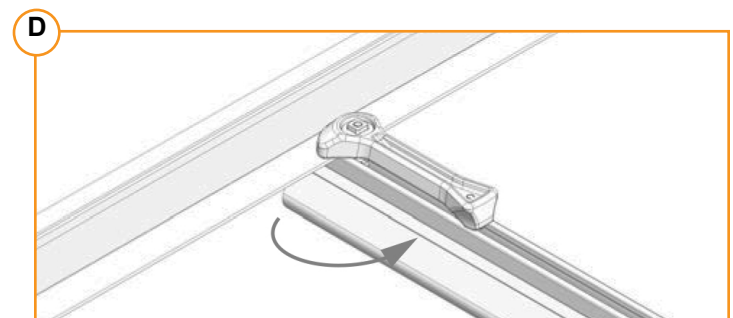

FRAME COMPATIBILITY

CAMO has been tested or evaluated with all modules listed in the Module Compatibility section having frames within the referenced dimensions. Be sure the specific module being used meets the dimension requirements.

- For installations with Hanwha Q CELLS modules with 32 mm frame heights, the maximum ground snow is 45 PSF (33 PSF module pressure).
- CAMO is only compatible with Canadian Solar modules CS1YxxxMS, CS3N-xxxMS, CS6R-xxxMS-HL and CS6W-xxxxMB-AG. "xxx" refers to the module power rating.

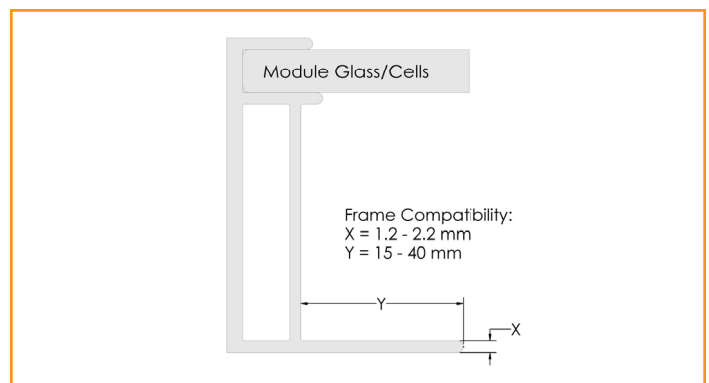

EXPANSION JOINTS

Expansion Joints are required every 100' of continuous rail to allow for thermal expansion and contraction of the system.

➤ Do not install modules over expansion joints.

BOSS

Insert BOSS into first Rail up to the Alignment Circle, Slide second Rail over BOSS to the second Alignment Circle, leaving a 1" gap between the Rails.

There must be a 1" of space between the edge of the Rail and the edge of the panel to allow proper installation of the UFO and Stopper Sleeve.

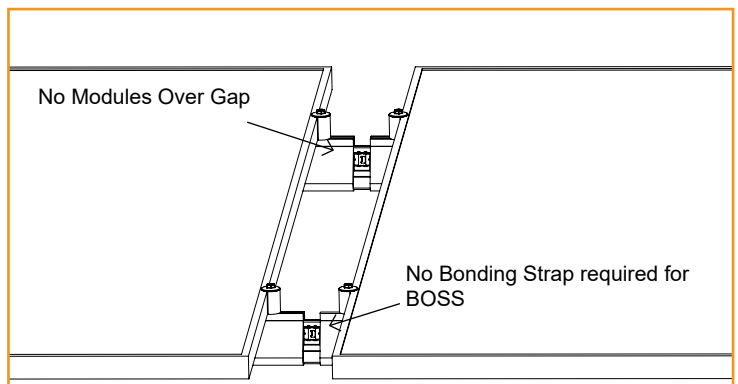
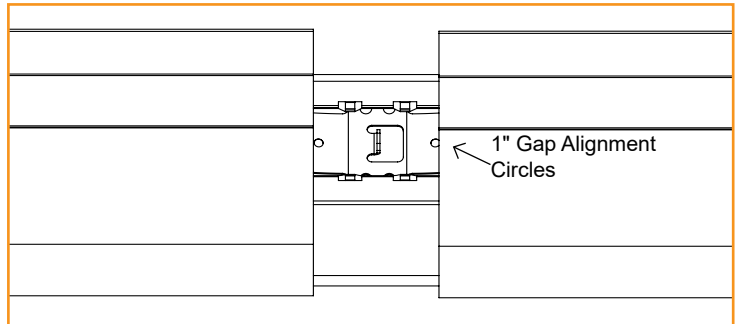

ELECTRICAL DIAGRAM

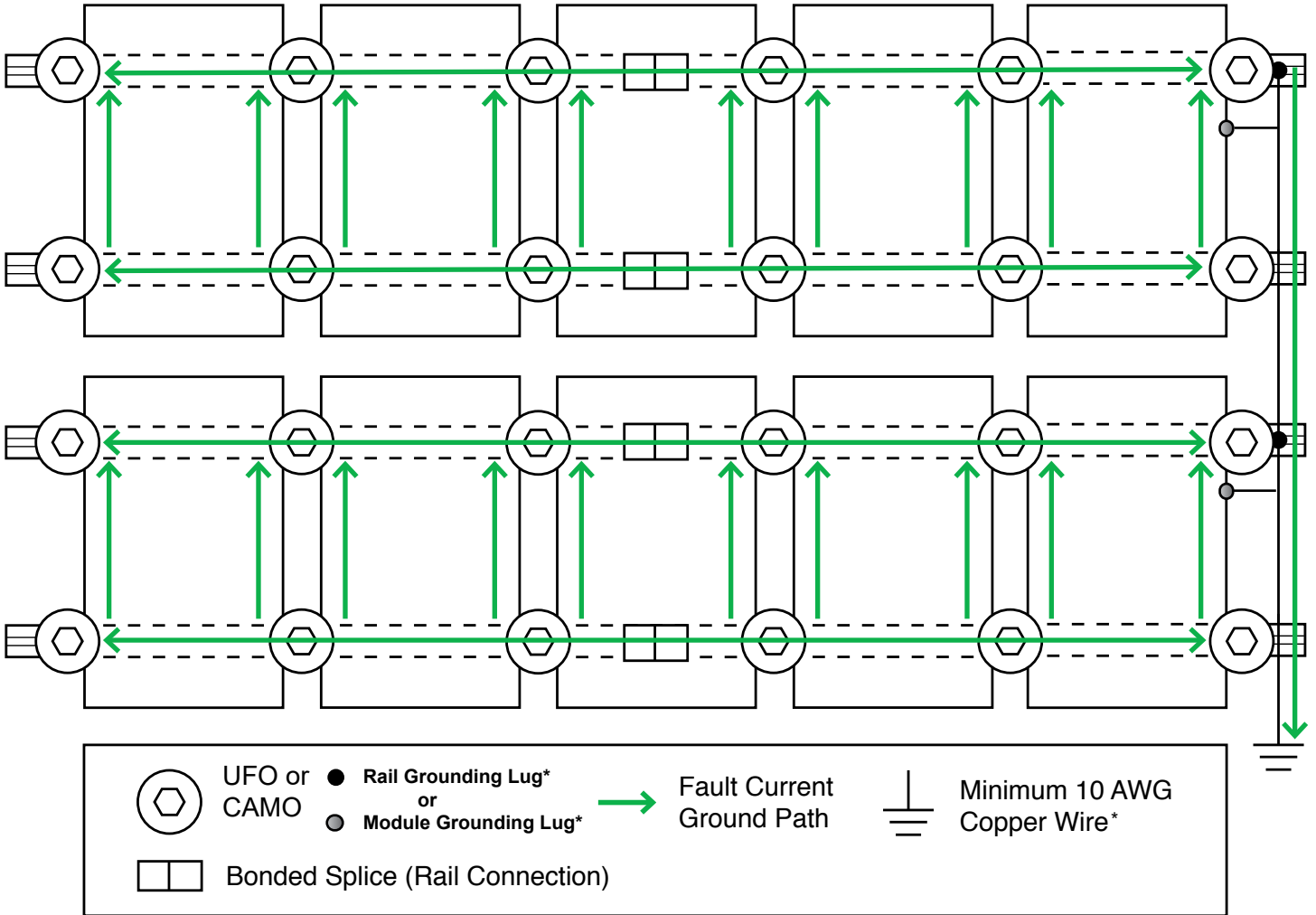

*One Module Grounding Lug or Rail Grounding lug is required per row of a system. Grounding Lugs and wire are not required in systems using certain Enphase microinverters or certain Sunpower modules. Equipment grounding is achieved with the Engage cable for Enphase or the AC module cable system for Sunpower via their integrated EGC.

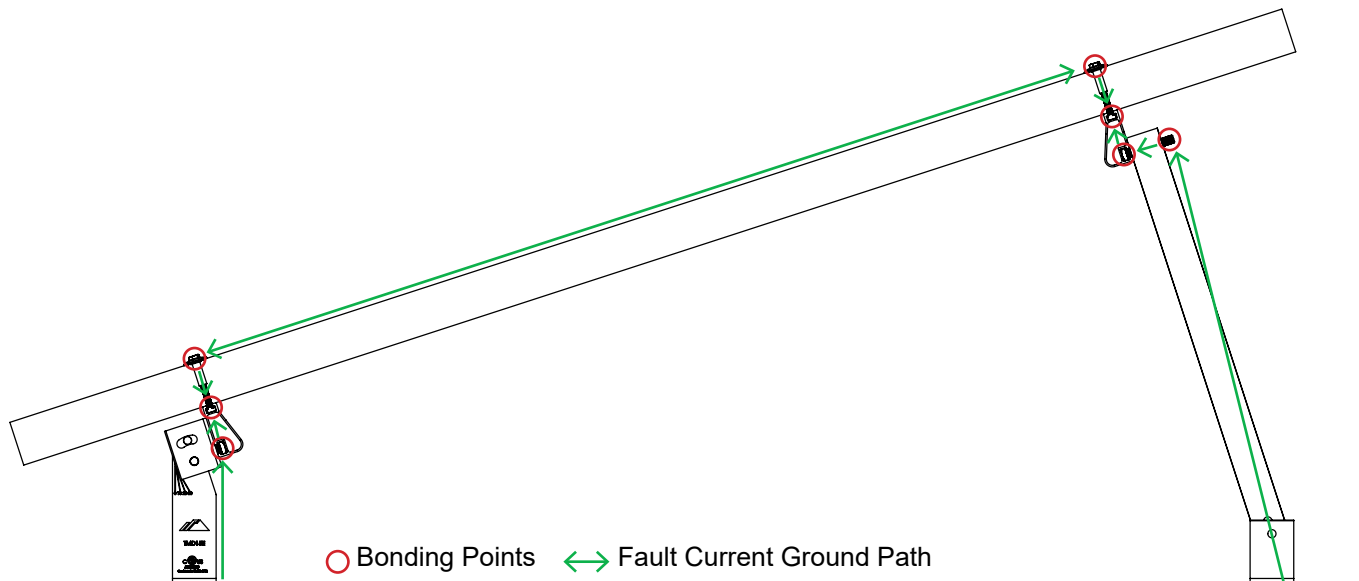

END CAPS

End Caps add a completed look and keep debris and pests from collecting inside rail.

Firmly press End Cap onto rail end.

- End Caps come in sets of left and right. Check that the proper amount of each has been provided.
- For open-structure installations, you can use adhesive to secure the End Caps.

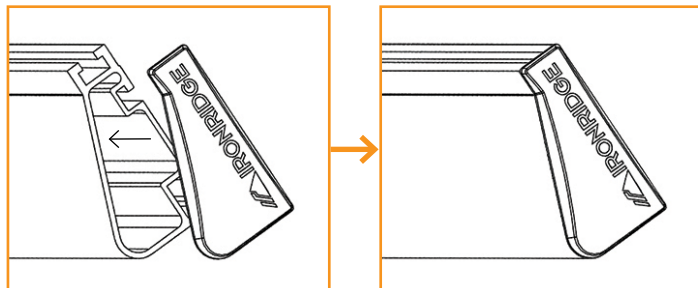

WIRE CLIPS

Wire Clips offer a simple wire management solution.

Firmly press Wire Clip into top rail slot. Run electrical wire through open clip. Snap closed once all wires have been placed.

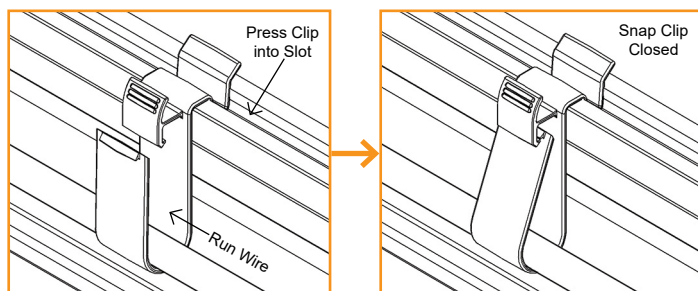

SYSTEMS USING MICROSTORAGE PRODUCTS

Use IronRidge's Microinverter Kit to bond compatible microstorage devices to the racking system. Insert Microinverter Kit T-bolt into top rail slot. Place compatible microstorage into position and tighten hex nut to **80 in-lbs**.

COMPATIBLE PRODUCTS

PHAZR

PHAZR Devices PHAZR-X, where X is 6-12.

- Running a separate equipment grounding conductor to the PHAZRs is not required.
- If installing in areas with ground snow loads greater than 40 psf and underneath a module, install PHAZR devices as close as possible to module frame edge.
- Use the number of IronRidge Microinverter kits allowed by the MLPE mounting flange. Some will require 1 kit and others 2 kits.

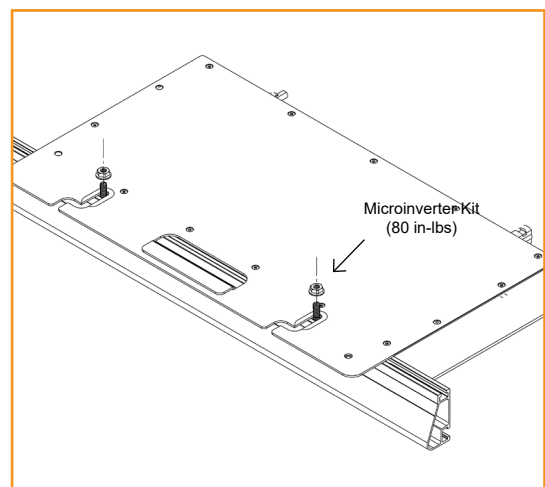

MICROINVERTER KITS

Use IronRidge's Microinverter Kit to bond compatible microinverters and power optimizers to the racking system.

Insert Microinverter Kit T-bolt into top rail slot. Place compatible microinverter or power optimizer into position and tighten hex nut to **80 in-lbs**.

- MLPE devices shall be installed near modules frames whenever possible.

COMPATIBLE PRODUCTS

Enphase

M250-72, 250-60, M215-60, C250-72, S230, S280, IQ 6, IQ 6+, IQ IQ7, IQ 7A, IQ 7+, IQ7 PD, IQ 7X, Q Aggregator; IQ8-60, IQ8PLUS-72, IQ8A-72, IQ8H-208-72, IQ8H-240-72, IQ8M-72, may be followed by -2-US

Darfon

MIG240, MIG300, G320, G640

Solar Edge

M1600, P300, P320, P340, P370, P400, P401, P405, P485, P505, P600, P700, P730, P750, P800p, P800s, P801, P850, P860, P950, P960, P1100, P1101, S440, S500, S500B, S650B, S1200, S1201

SMA

RoofCommKit-P2-US, TS4-R Module Retrofit Kits (TS4-R-S, TS4-R-O, TS4-R-F)

Tigo

Tigo Access Point (TAP)

TS4-R-X (where X can be F, M, O, or S)

TS4-R-X-DUO (where X can be M, O, or S)

TS4-A-X (where X can be F, 2F, O, O-DUO, or S)

Generac

S2502

AP Systems

DS3, QS1, QT2 and YC600

NEP

BDM-300, BDM-300X2, BDM-550, BDM-650 and BDM-800

Hoymiles

HM-xxxNT

where xxx can be 300, 350, 400, 600, 700 and 800

Yotta

DPI 208/480

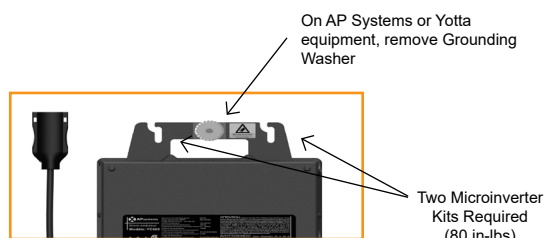
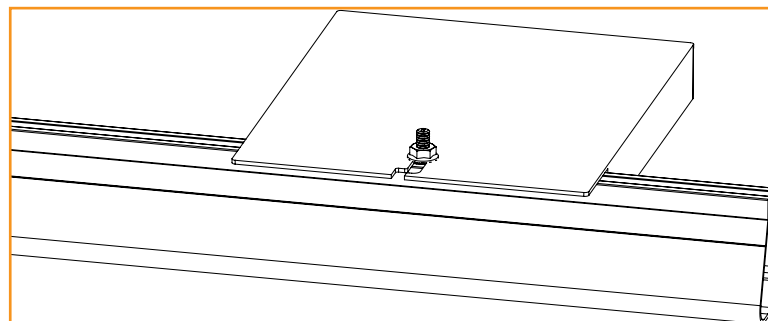
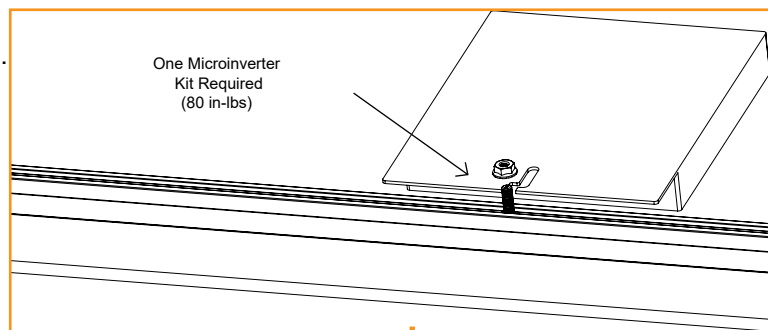

- Remove Grounding Washer on AP Systems QS1, QT2, DS3 and YC600 and Yotta inverters before installing to XR rails.
- Remove the Stainless Steel Clip on Tigo-"A" MLPE Devices before attaching to XR rails.
- Use the number of IronRidge Microinverter kits allowed by the MLPE mounting flange. Some will require 1 kit and others 2 kits.

SYSTEMS USING ENPHASE MICROINVERTERS OR SUNPOWER AC MOD-

IronRidge systems using approved Enphase products or SunPower modules eliminate the need for lay-in lugs and field installed equipment grounding conductors (EGC). This solution meets the requirements of UL 2703 for bonding and grounding and is included in this listing.

COMPATIBLE PRODUCTS

Sunpower

Modules with model identifier Ab-xxx-YY and InvisiMount (G5) 46mm frame; where "A" is either E, or X; "b" can be 17, 18, 19, 20, 21, or 22; and "YY" can be C-AC, D-AC, BLK-C-AC, or BLK-D-AC.

Enphase

Microinverters M250-72, M250-60, M215-60, C250-72, and Engage cables ETXX-240, ETXX-208, ETXX-277.

- A minimum of two inverters mounted to the same rail and connected to the same Engage cable are required.
- The microinverters or Sunpower AC modules must be used with a maximum 20 A branch rated overcurrent protection device (OCPD).
- If an AC module is removed from a circuit for maintenance, you must first disconnect AC power and then install a temporary EGC to bridge the gap by inserting an AC extension cable (or via other NEC-compliant means), in order to maintain effective ground continuity to subsequent modules.

FRAMELESS MODULE KITS

Insert Frameless Kit T-bolt in top rail slot. Place star washer over T-bolt, allowing it to rest on top of rail. Secure module clamps with a hex nut and torque to **80 in-lbs**.

COMPATIBLE PRODUCTS

Sunforson

Sunforson silver or black SFS-UTMC-200(B) mid and SFS-UTEC-200(B) end clamps.

Sunpreme

Sunpreme silver or black mid and end clamps with part numbers 7500105X where "X" is 1, 5, 6 or 7.

Ironridge

IronRidge silver or black mid and end clamps with part numbers FMLS-XC-001-Y where "X" is E or M and "Y" is B or blank.

- Follow module manufacturer's installation instructions to install the module clamps.
- Frameless modules require using a Grounding Lug on every rail.
- For Sunpreme Modules Only: If required to use slide prevention hardware, see Module Slide Prevention Addendum (Version 1.10).

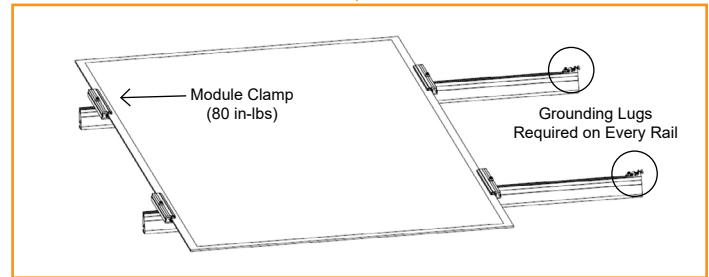
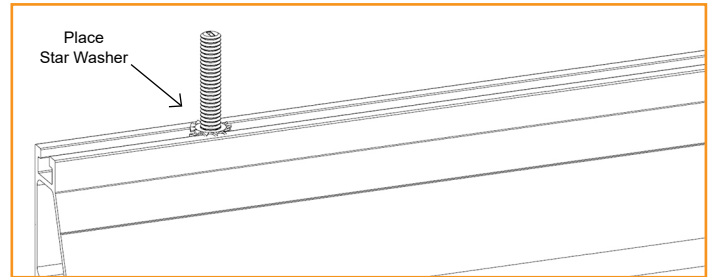

MODULE COMPATIBILITY

The Tilt Mount System has been tested and evaluated to UL 2703 for bonding, grounding, mechanical loading and fire classification, and may be used to ground and/or mount PV modules listed to UL 1703 or UL 61730. A list of approved modules is included below. Unless otherwise noted, "xxx" refers to the module power rating and both black and silver frames are included in the certification.

FRAMED MODULE LIST	
MAKE	MODELS
Adani	Adani modules with 35 and 40 mm frames ASX-Y-ZZ-xxx Where "X" can be B, M or P; "Y" can be 6, 7 or M10 and "ZZ" can be blank, 144, PERC, B-PERC, or AB-PERC
AIONRISE	AIONRISE modules with 35 and 40 mm frames AIONyyG1-xxx Where "yy" can be 60 or 72
Amerisolar	Amerisolar modules with 35 and 40 mm frames AS-bYxxxZ Where "b" can be 5 or 6; "Y" can be M, P, M27, P27, M30, or P30; and "Z" can be blank, W or WB
Aptos Solar	Aptos modules with 35 and 40 mm frames DNA-yy-zzaa-xxx Where "yy" can be 108, 120 or 144; "zz" can be MF or BF; and "aa" can be 10, 23 or 26
Astronergy Solar	Astronergy modules with 30, 35 and 40 mm frames aaSMbbyyC/zz-xxx Where "aa" can be CH or A; "bb" can be 60, 66, or 72; "yy" can be blank, 10 or 12; "C" can M, P, M(BL), M-HC, M(BL)-HC, P-HC, M(DG), or M(DGT); and "zz" can be blank, HV, F-B, or F-BH
ASUN	ASUN modules with 35 and 40 mm frames ASUN-xxx-YYZZ-aa Where "YY" can be 60 or 72; "ZZ" can be M, or MH5; and "aa" can be blank or BB
Auxin	Auxin modules with 35 and 40 mm frames AXNCyzAxxxB Where "C" can be 6, 10 or G1; "y" can be M or P; "z" can be blank, 08, 09, 610, 11, or 612; and "A" can be blank, F, M or T; and "B" can be blank, A, B, C or W
Axitec	Axitec Modules with 30, 35 and 40 mm frames AC-xxxY/aaZZb Where "Y" can be M, P, MB, MBT or MH; "aa" can be blank, 125- or 156-; "ZZ" can be 54, 60, 72, 108, 120, or 144; "b" can be S, X, V, VB, XV, or MX
Bluesun Solar	Bluesun modules with 30 and 35 mm frames BSMxxxY-AAA Where "Y" can be M or M10; and "AAA" can be 54HPH, 60HPH or 72HBD
Boviet	Boviet modules with 35 and 40 mm frames BVMZZaaYY-xxxBcc Where "ZZ" can be 66 or 76; "aa" can be 9, 10 or 12; "YY" is M or P; and "B" can be blank, L or S; and "cc" can be blank, H, H-BF, H-BF-DG, H-HC, H-HC-BF, H-HC-BF-DG, HC-BF or HC-BF-DG
BYD	BYD modules with 35 mm frames BYDxxxAY-ZZ Where "A" can be M6, P6, MH, MLT or PH; "Y" can be C or K; and "ZZ" can be 30 or 36
Canadian Solar	Canadian Solar modules with 30, 32, 35 and 40 mm frames CSbY-xxxZ Where "b" can be 1, 3, 6 or 7 "Y" can be H, K, L, N, P, R, U, V, W, X or Y; and "Z" can be M, P, MS, PX, M-SD, P-AG, P-SD, MB-AG, PB-AG, MS-AG, MS-HL, or MS-SD
CertainTeed	CertainTeed modules with 30, 35 and 40 mm frames CTBBxxxYZZ-AA Where "BB" can be blank or M10; "Y" can be M, P, or HC; "ZZ" can be 00, 01, 10, or 11; and "AA" can be 01, 02, 03, 04, 06, 08 or 09

MODULE COMPATIBILITY

Crossroads Solar	Crossroads Solar modules with 40 mm frames Crossroads Solar xxx
CSUN	Csun modules with 35 and 40 mm frames YYxxx-zzAbb Where "YY" is CSUN or SST; "zz" is blank, 60, or 72; and "A" is blank, P, M or MM; "bb" is blank, BB, 5BB, BW, or ROOF
Dehui	Dehui modules with 30, 35 and 40 mm frames DH-MYYYY-xxx Where "YYY" can be 760, 772, 860, 872; and "Z" can be B, F or W
Ecosolargy	Ecosolargy modules with 35 and 40 mm frames ECOxxxYzzA-bbD Where "Y" can be A, H, S, or T; "zz" can be 125 or 156; "A" can be M or P; "bb" can be 60 or 72; and "D" can be blank or B
Emmvee	Emmvee modules with 35 mm frames Exxx-YYZZZ-A Where "YY" can be M, P, HCM, HCMW, HCBG, HCBT; "ZZZ" can be 72, 120 or 144; and "A" can be blank or B
ET Solar	ET Solar modules with 30, 35 and 40 mm frames ET-YYYYxxxAA Where "Y" can be P, L, or M; "ZZZ" can be 660, 660BH, 672, 672BH, 754BH, 766BH, 772BH; and "AA" can be GL, TB, TW, WB, WW, BB, WBG, WWG, WBAC, WBCO, WWCO, WWBCO or BBAC
Flex	Flex modules with 35 and 40 mm frames FXS-xxxYY-ZZ; Where "YY" can be BB or BC; and "ZZ" can be MAA1B, MAA1W, MAB1W, SAA1B, SAA1W, SAC1B, SAC1W, SAD1W, SBA1B, SBA1W, SBC1B, or SBC1W
Freedom Forever	Freedom Forever modules with 35 mm frames FF-MPa-BBB-xxx Where "a" can be blank or 1
Freevolt	Freevolt modules with 35 mm frames ECP-PVGRAF-144HC-xxx
GCL	GCL modules with 35 mm and 40 mm frames GCL-ab/YY xxx Where "a" can be M or P; "b" can be 3 or 6; and "YY" can be 60, 72, 72H, or 72DH
GigaWatt Solar	Gigawatt modules with 40 mm frames GWxxxYY Where "YY" can be either PB or MB
Goldi	Goldi modules with 35 mm frames GS10-Byyy-zz-xxx Where "yyy" can be 108 or 144; and "zz" can be GF or TF
Grape Solar	Grape modules with 35 mm frames GS-M120-xxx-FAB1
Hansol	Hansol modules with 35 and 40 mm frames HSxxxYY-zz Where "YY" can be PB, PD, PE, TB, TD, UB, UD, or UE; and "zz" can be AH2, AN1, AN3, AN4, HH2, HV1, or JH2
Hanwa Solar	Hanwha Solar modules with 40 mm frames HSLaaP6-YY-1-xxxZ Where "aa" can be either 60 or 72; "YY" can be PA or PB; and "Z" can be blank or B

MODULE COMPATIBILITY

Hanwha Q CELLS	<p>Hanwha Q CELLS Modules with 32, 35, 40 mm frames aaYY-ZZ-xxx where "aa" can be Q. or B.; "YY" can be PLUS, PRO, PEAK, LINE PRO, LINE PLUS, PLUS DUO or PEAK DUO; and "ZZ" can be G3, G3.1, G4, G4.1, L-G2, L-G2.3, L-G3, L-G3.1, L-G3y, L-G4, L-G4.2, L-G4y, LG4.2/TAA, BFR-G3, BLK-G3, BFR-G3.1, BLK-G3.1, BFR-G4, BFR-G4.1, BFR G4.3, BLK-G4.1, G4/SC, G4.1/SC, G4.1/TAA, G4.1/MAX, BFR G4.1/TAA, BFR G4.1/MAX, BLK G4.1/TAA, BLK G4.1/SC, EC-G4.4, G5, G5/SC, G5/TS, BLK-G5, BLK-G5/SC, BLK-G5/TS, L-G5, L-G5.1, L-G5.2, L-G5.2/H, L-G5.3, G6, G6/SC, G6/TS, G6+/TS, G6+, BLK-G6, L-G6, L-G6.1, L-G6.2, L-G6.3, G7, BLK-G6+, BLK-G6+/AC, BLK-G6+/HL, BLK-G6+/SC, BLK-G6/TS, BLK-G6+/TS, BLK-G7, G7.2, G8, BLK-G8, G8+, BLK-G8+ L-G7, L-G7.1, L-G7.2, L-G7.3, L-G8, L-G8.1, L-G8.2, L-G8.3, L-G8.3/BFF, L-G8.3/BFG, L-G8.3/BGT, ML-G9, BLK ML-G9, ML-G9+, BLK ML-G9+, BLK-G10+, BLK G10+/AC, ML-G10, BLK ML-G10, ML-G10+, BLK ML-G10+, ML-G10.a, BLK ML-G10.a, ML-G10.a+, BLK ML-G10.a+, BLK ML-G10 +/t, BLK ML-G10+/TS, XL-G9, XL-G9.2, XL-G9.3, XL-G9.3/BFG, XL-G10.2, XL-G10.3, XL-G10.c, XL-G10.d, XL-G10.d/BFG, XL-G10.3/BFG, XL-G11.2, XL-G11.3, XL-G11.3/BFG or XL-G11S.3/BFG</p>
Heliene	<p>Heliene modules with 35 and 40 mm frames YYZZxxxA Where "YY" can be 36, 60, 72, 96, 108, 120, 132, 144 or 156; "ZZ" can be HC, M, P, or MBLK; and "A" can be blank, HomePV, Bifacial, M10-SL, M10-SL-BLK, M10 Bifacial or M10 SL-Bifacial</p>
HT-SAAE	<p>HT-SAAE modules with 35 and 40 mm frames HTyy-aaaZ-xxx Where "yy" can be 60, 66, 72 or 78, "aaa" can be 18, 156 or 166, "Z" can be M, P, M-C, P-C, M(S), M(VS), M(V), P(V), M(V)-C, P(V)-C, or X</p>
Hyperion Solar (Runergy)	<p>Hyperion modules with 30 and 35 mm frames HY-DHzzzA8-xxxB Where "zzz" can be 108 or 144; "A" can be N or P; and "B" can be blank or B</p>
Hyundai	<p>Hyundai modules with 32, 33, 35 and 40 mm frames HiY-SxxxZZ Where "Y" can be A, D or S; "S" can be M or S; and "ZZ" can be GI, HG, HI, KI, MI, MF, MG, PI, RI, RG, RG(BF), RG(BK), SG, TI, TG, YH(BK) or XG(BK)</p>
Itek	<p>Itek Modules with 40 mm frames IT-xxx-YY Where "YY" can be blank, HE, or SE, or SE72</p>
JA Solar	<p>JA Solar modules with 30, 35 and 40 mm frames JAyyzz-bbww-xxx/aa Where "yy" can be M, P, M6 or P6; "zz" can be blank, (K), (L), (R), (V), (BK), (FA), (TG), (FA)(R), (L)(BK), (L)(TG), (R)(BK), (R)(TG), (V)(BK), (BK)(TG), or (L)(BK)(TG); "bb" can be 48, 54, 60, 66, 72 or 78; "ww" can be D09, D10, D20, D30, S01, S02, S03, S06, S09, S10, S12, S17, S20, S30 or S31; and "aa" can be BP, MB, MR, SI, SC, PR, 3BB, 4BB, 4BB/RE, 5BB</p>
Jinko	<p>Jinko modules with 35 and 40 mm frames JKMYxxxZZ-aa Where "Y" can either be blank or S; "ZZ" can be M, P, or PP; and "aa" can be blank, 60, 60B, 60H, 60L, 60BL, 60HL, 60HB, 60HBL, 6HBL-EP, 60-J4, 60B-J4, 60B-EP, 60(Plus), 60-V, 60-MX, 6RL3, 6RL3-B, 6TL3-B, 7RL3-V, 7RL3-TV, 72, 72B, 72-J4, 72B-J4, 72(Plus), 72-V, 72H-V, 72L-V, 72HL-V, 72HBL-V, 72HL4-V, 72HL4-TV, 72-MX, 72H-BDVP, 72HL-TV, or 72HL-V-MX3</p>
Kyocera	<p>Kyocera Modules KYxxxZZ-AA Where "Y" can be D or U; "ZZ" can be blank, GX, or SX; and "AA" can be LPU, LFU, UPU, LPS, LPB, LFB, LFBS, LFB2, LPB2, 3AC, 3BC, 3FC, 4AC, 4BC, 4FC, 4UC, 5AC, 5BC, 5FC, 5UC, 6BC, 6FC, 8BC, 6MCA, or 6MPA</p>
LG	<p>LG modules with 35 and 40 mm frames LGxxxYaZ-bb Where "Y" can be A, E, M, N, Q, S; "a" can be A, 1, 2 or 3 "Z" can be C, K, T, or W; and "bb" can be A3, A5, A6, B3, B6, E6, E6.AW5, G3, G4, J5, K4, L5, N5, V5, V6</p>

MODULE COMPATIBILITY

Longi	Longi modules with 30, 35 and 40 mm frames LRa-YYZZ-xxxM Where "a" can be 4, 5 or 6; "YY" can be blank, 54, 60, 66, or 72; and "ZZ" can be blank, BK, BP, HV, PB, PE, PH, HBD, HIB, HIH, HPB, HPH, or HIBD
Maxeon	Maxeon modules with 35, 40 and 46 mm frames SPR-AAAY-xxx-zzz Where "AAA" can be MAX, P or X; "Y" can be 3, 5, 6, 21 or 22; and "zzz" can be R, BLK, COM or UPP
Meyer Burger	Meyer Burger Modules with 35 mm frames Meyer Burger Black, White or Glass
Mission Solar (mSolar)	Mission Solar modules with 33, 35 and 40 mm frames YYYYbb-xxxZZaa Where "YYYY" can be MSE, TXI or TXS; "bb" can be blank, 6, 10 or 60A; "ZZ" can be blank, MM, SE, SO, SQ, SR, SX, TS, 108, 120 or 144; and "aa" can be blank, BB, BW, 1J, 4J, 4S, 5K, 5R, 5T, 60, 6J, 6S, 6W, 6Z, 8K, 8T, 9R, 9S or 9Z
Mitrex	Mitrex modules with 30 and 40 mm frames Mxxx-XYZ Where "X" can be A, B, I or L; "Y" can be 1 or 3; and "Z" can be F or H
Mitsubishi	Mitsubishi modules PV-MYYxxxZZ Where "YY" can be LE or JE; and "ZZ" can be either HD, HD2, or FB
Moltech	IM and XS series modules with 40 mm frames
Next Energy Alliance	Next Energy Alliance modules with 35 and 40 mm frames yyNEA-xxxZZ where "yy" can be blank or US; "ZZ" can be M, MB or M-60
NE Solar	NE Solar modules with 30, 35 and 40 mm frames NESExx-zzMHX-yy Where "zz" can be 54, 60 or 72; "X" can be blank or B; and "yy" can be M6 or M10
Neo Solar Power	Neo Solar Power modules with 35 mm frames D6YxxxZZaa Where "Y" can be M or P; "ZZ" can be B3A, B4A, E3A, E4A, H3A, H4A; and "aa" can be blank, (TF), ME or ME (TF)
Panasonic (HIT)	Panasonic modules with 35 and 40 mm frames VBHNxxxYyzzA Where "YY" can be either KA, RA, SA or ZA; "zz" can be either 01, 02, 03, 04, 06, 06B, 11, 11B, 15, 15B, 16, 16B, 17, or 18; and "A" can be blank, E, G, or N
Panasonic (EverVolt)	Panasonic modules with 30 mm frames EVPVxxxA Where "A" can be blank or H, K, HK or PK
Peimar	Peimar modules with 40 mm frames SbxxxYzz Where "b" can be G, M or P; "Y" can be M or P; and "zz" can be blank, (BF) or (FB)
Philadelphia Solar	Philadelphia modules with 30, 35 and 40 mm frames PS-YzzAA-xxxW Where "Y" can be M or P; "zz" can be 60, 72, 108 or 144; "AA" can be blank, (BF), (HC) or (HCBF); and "W" can be blank or W
Phono Solar	Phono Solar modules with 30, 35 and 40 mm frames PSxxxY-ZZ/A Where "Y" can be M, M1, MH, M1H, M4, M4H, M5GF, M5GFH, M6, M6H, M8, M8H, M8GF, M8GFH or P; "ZZ" can be 18, 20 or 24; and "A" can be F, T, TH, THB, U, UH, UHB, VH or VHB
Prism Solar	Prism Solar modules with 35 mm frames PST-xxxW-M72Y Where "Y" can be H, HB or HBI

MODULE COMPATIBILITY

Recom	Recom modules with 35 and 40 mm frames RCM-xxx-6yy Where "yy" can be MA, MB, ME or MF
REC Solar	REC modules with 30 and 38 mm frames RECxxxYYZZ Where "YY" can be AA, M, NP, NP2, NP3, PE, PE72, TP, TP2, TP2M, TP2SM, TP2S, TP3M or TP4; and "ZZ" can be blank, Black, BLK, BLK2, SLV, 72, Pure or Pure-R
Renesola	ReneSola modules with 35 and 40 mm frames AAxxxY-ZZ Where "AA" can be SPM(SLP) or JC; "Y" can be blank, F, M or S; and "ZZ" can be blank, Ab, Ab-b, Abh, Abh-b, Abv, Abv-b, Bb, Bb-b, Bbh, Bbh-b, Bbv, Bbv-b, Db, Db-b, or 24/Bb
Renogy	Renogy Modules with 35 and 40 mm frames RZZ-xxxY-AAA Where "ZZ" can be NG or SP; "Y" can be D or P; and "AAA" can be 144, BB-108, BB-120 or BK-120
Risen	Risen Modules with 30, 35 and 40 mm frames RSMyy-a-xxxZZ Where "yy" can be 60, 72, 110, 120, 132 or 144; "a" can be 6, 7 or 8; and "ZZ" can be M, P or BMDG
Saatvik	Saatvik Modules with 35 mm frames SGExxx-YYYZZZ Where "YYY" can be 108 or 144; and "ZZZ" can be MHC, MBHC or MHCB
S-Energy	S-Energy modules with 35 and 40 mm frames SABB-CCYYY-xxxZ Where "A" can be C, D, L or N; "BB" can be blank, 20, 25, 40 or 45; "CC" can be blank, 60 or 72; "YYY" can be blank, BDE, MAE, MAI, MBE, MBI, MCE or MCI; and "Z" can be V, M-10, P-10 or P-15
SEG Solar	SEG Solar with 30, 35 and 40 mm frames SEG-aYY-xxxZZ Where "a" can be blank, 6 or B; "YY" can be blank, MA, MB, PA, or PB; and "ZZ" can be blank, BB, BG, BW, HV, WB, WW, BMB, BMA-HV, BMA-BG, BMA-TB, BMB-TB, BMB-HV, BMD-HV, BMB-BG
Seraphim USA	Seraphim modules with 30, 35 and 40 mm frames SRP-xxx-YYY-ZZ Where "xxx" is the module power rating; and "YYY" can be BMA, BMD, 6MA, 6MB, 6PA, 6PB, 6QA-XX-XX, and 6QB-XX-XX; ZZ is blank, BB, BG or HV
Sharp	Sharp modules with 35 and 40 mm frames NUYYxxx Where "YY" can be SA or SC
Shinsung E&G	Shinsung Modules with 35 mm frames SSVxxx-144MH
Silfab	Silfab Modules with 35 and 38 mm frames SYY-Z-xxxAb Where "YY" can be IL, SA, LA, SG or LG; "Z" can be blank, M, P, or X; "A" can be blank, B, H, M, N; and "b" can be A, C, C+, G, K, L, M, N, T, U or X
Sirius PV	Sirius PV Modules with 35 mm frames ELNSMzzM-HC-xxx Where "zz" can be 54 or 72
Solar4America	Solar4America modules with 30, 35 and 40 mm frames S4Axxx-YYzzAA Where "YY" can be 72, 108 or 144; "zz" can be MH5 or MH10; and "AA" can be blank or BB, SW or STT
Solarever	Solarever modules with 35 mm frames SE-zzz*yy-xxxM-aaa Where "zzz" can be 166 or 182; "yy" can be 83 or 91; and "aaa" can be 108, 144 or 144N
Solaria	Solaria modules with 35 and 40 mm frames PowerA-xxxY-ZZ Where "A" can be X or XT, "Y" can be R or C; and "ZZ" can be blank, AC, BD, BX, BY, PD, PL, PM, PM-AC, PX, PZ, WX or WZ

MODULE COMPATIBILITY

Solarcity (Tesla)	Solarcity modules with 40 mm frames SCxxxYY Where "YY" can be blank, B1 or B2
SolarTech	SolarTech modules with 40 mm frames AAA-xxxYY Where "AAA" can be PERCB-B, PERCB-W, HJT-B, HJT-W or STU; "YY" can be blank, PERC or HJT
SolarWorld AG	SolarWorld Sunmodule Plus, Protect, Bisun, XL, Bisun XL, may be followed by mono, poly, duo, black, bk, or clear; modules with 31 and 33 mm frames SW-xxx
SolarWorld Americas	SolarWorld Sunmodule Plus, Protect, Bisun, XL, Bisun XL, may be followed by mono, poly, duo, black, bk, or clear; modules with 33 mm frames SWA-xxx
Sonali	Sonali Modules with 35 and 40 mm frames SS-M-xxx Where "M" can be blank or M
Star Solar	Star Solar modules with 35 mm frames Star-xxxW-YYY-ZZZ Where "YYY" can be M60H or M60HB; and "ZZZ" can be blank or M10
Stion	Stion Thin film modules with 35 mm frames STO-xxx or STO-xxxA
SunEdison	SunEdison Modules with 35 and 40 mm frames SE-YxxxZABCDE Where "Y" can be B, F, H, P, R, or Z; "Z" can be 0 or 4; "A" can be B,C,D,E,H,I,J,K,L,M, or N; "B" can be B or W; "C" can be A or C; "D" can be 3, 7, 8, or 9; and "E" can be 0, 1 or 2
Suniva	Suniva modules with 35, 38 and 40 mm frames OPTxxx-AA-B-YYY-Z MVXxxx-AA-B-YYY-Z Where "AA" is either 60 or 72; "B" is either 4 or 5; "YYY" is either 100,101,700,1B0, or 1B1; and "Z" is blank or B
Sunmac Solar	Sunmac modules with 30 and 35 mm frames SMxxxMaaaZZ-YY Where "aaa" can be 660, 754 or 772; "ZZ" can be NH or SH; and "YY" can be BB or TB
Sunpower	Sunpower standard (G3 or G4) or InvisiMount (G5) 35 and 40 mm frames SPR-Zb-xxx-YY Where "Z" can be A, E, M, P or X; "b" can be blank, 17, 18, 19, 20, 21, or 22; and "YY" can be blank, BLK, COM, C-AC, D-AC, E-AC, BLK-E-AC, G-AC, BLK-G-AC, H-AC, BLK-H-AC, BLK-C-AC, or BLK-D-AC
Sunspark	Sunspark modules with 40 mm frames SYY-xxxZ-A Where "YY" can be MX or ST; and "Z" can be M, MB, M3, M3B, P or W; and "A" can be 60 or 72
Suntech	Suntech modules with 35 and 40 mm frames STPxxx-y-zz/aa Where "y" is blank or S; and "zz" can be 20, 24, A60, A72U, B60 or B72; and "aa" can be Vd, Vem, Vfw, Vfh, Vnh, Wdb, Wde, Wd, Wfhh or Wnhb
Talesun	Talesun modules with 30, 35 and 40 mm frames TAByZZaa-xxx-b Where "A" can be D or P; "B" can be 6 or 7; "y" can be blank, F, G, H, I or L; "ZZ" can be 54, 60, 66, 72 or 78; "aa" can be M, M(H), or P; and "b" can be blank, B, T, or (H)
Tesla	Tesla modules with 40 mm frames TxxxY Where "Y" can be H or S

MODULE COMPATIBILITY

Thornova	Thornova Modules with 30 and 35 mm frames TS-YYZZ(xxx)-X Where "YY" can be BB or BG; "ZZ" can be 54, 60 or 72; and "X" can be blank or X
Trina	Trina Modules with 30, 35 and 40 mm frames TSM-xxxYYZZ Where "YY" can be DD05, DD06, DD14, DE14, DE15, DE15V, DEG15, DEG15VC, DE18M, DEG18MC, DE09, DE19, DEG19C.20, DE06X, PA05, PC05, PD05, PD06, PA14, PC14, PD14, PE14, PE15 or NE-G19RC ; and "ZZ" can be blank, .05, .05(II), .08, .08(II), .10, .18, .08D, .18D, 0.82, .002, .00S, 05S, 08S, .20, .20(II), A, A.05, A.08, A.10, A.18, (II), A(II), A.05(II), A.08(II), A.082(II), A.10(II), A.18(II), C.05, C.07, C.05(II), C.07(II), H, H(II), H.05(II), H.08(II), HC.20(II), HC.20(II), M, M(II), M.05(II), MC.20(II)
Universal	Universal Solar modules with 35 mm frames UNI-xxx-yyyZZZ-aa Where "yyy" can be 108, 120 or 144; "ZZZ" can be M, MH, BMH; and "aa" can be blank, BB or DG
URE	URE modules with 35 mm frames DyZxxxaa Where "D" can be D or F, "y" can be A, B, 6 or 7; "Z" can be K, L or M; and "aa" can be C8G, H3A, H4A, H8A, L4A, E7G-BB, E8G, E8G-BB, MFG-BB or M7G-BB
Vikram	Vikram solar modules with 35 and 40 mm frames XVSyy.ZZ.AAA.bb Where "X" can be blank, Paradea, Prexos or Somera; "yy" can be M, P, MBB, MDH, MDHT, MH, MS, MHBB, or PBB; "ZZ" can be 54, 60 or 72; "AAA" is the module power rating; and "bb" can be 03, 04 or 05
VSUN	VSUN modules with 30, 35 and 40 mm frames VSUNxxx-YYz-aa Where "YY" can be 60, 72, 108, 120, 132 or 144; "z" can be M, P, MH, PH, or BMH; and "aa" can be blank, BB, BW, or DG
Waaree	Waaree modules with 35 and 40 mm frames AAyy-xxx Where "AA" can be WS or Bi; and "yy" can be blank, M, MB, 55 or 66
Winaico	Winaico modules with 35 and 40 mm frames Wsy-xxxZa Where "y" can be either P or T; "Z" can be either M, P, or MX; and "a" can be blank or 6
Yingli	Yingli modules with 30, 35 and 40 mm frames YLxxxZ-yy Where "Z" can be D or P; "yy" can be blank, 29b, 30b, 34d, 35b, 36b, 37e 1/2, 37e 1500V 1/2, 40d, 49e 1/2 or 49e 1500V 1/2
Yotta	Yotta modules with 30 and 35 mm frames YSM-Bxxx-ZZ-72-1 Where "ZZ" can be 06 or 10
Zeus	Zeus Solar Modules with 40 mm frames ZxxxM-HB
ZN Shine	ZN Shine modules with 30 and 35 mm frames ZXTMY-AAA-xxx/M Where "Y" can be 6, 7 or 8; "AAA" can be 72, NH120, NH144, NHDB144, NHLDD144, SH108, SH144, SHDB144, SHLDD144 or TP120

MODULE COMPATIBILITY

FRAMELESS MODULE LIST

MAKE	MODELS
Astronergy Solar	Astronergy frameless modules CHSM6610P(DG)-xxx
Canadian Solar	Canadian Solar frameless modules CSbY-xxx-Z Where "b" can be 3 or 6; "Y" is K, P, U, or X; and "Z" can be M-FG, MS-FG, P-FG, MB-FG, or PB-FG
Heliene	Heliene frameless modules YYZZxxxA Where "YY" can be 72; "ZZ" can be M; and "A" can be GH
Jinko	Jinko frameless modules JKMxxxPP-DV
Prism Solar	Prism Solar frameless modules BZYY-xxxAAA Where "Z" can be i or N; "YY" can be 48, 60, 60S, 72 or 72S; and "AAA" can be blank or BSTC
Risen	Risen frameless modules RSMyy-6-xxxZZ Where "yy" can be 60, 72, 120 or 144; and "ZZ" can be MDG or PDG
Stion	Stion frameless modules STL-xxx or STL-xxxA
Sunpreme	Sunpreme frameless modules GXB-xxxYY Where "YY" can be blank or SL
Trina	Trina frameless modules TSM-xxxYY Where "YY" can be either DEG5(II), DEG5.07(II), DEG5.40(II), DEG5.47(II), DEG14(II), DEG14C(II), DE- G14C.07(II), DEG14.40(II), PEG5, PEG5.07, PEG5.40, PEG5.47, PEG14, or PEG14.40